

GTC-550

55 US TON MAX. CRANE CAPACITY





January 2023. Unless otherwise specified, all information in this brochure refers to a standard crane equipment, and it is intended as general information only. No liability is assumed. Errors reserved. Product specifications and prices are subject to changes without notice. The photographs and/or drawings in this brochure are for illustrative purposes only. For correct and safe crane operation, the original operating manual and lifting capacity charts are essential. Failure to follow the corresponding Operator's Manual when using our equipment or failure to otherwise act responsibly may result in property damage, serious injury or death. The sole warranty applicable with respect to our equipment is the standard warranty as per general terms and conditions of sales and service (ask your local Tadano dealer for details), and Tadano makes no other warranty, express or implied. All rights reserved. Any use of the trademarks, logos, brand names and model names used herein is prohibited.

© Tadano Ltd. 2023

Contents

Specifications	5
Vehicle dimensions	6-7
General dimensions	7
Transportation	9
Transport dimensions	10
Operation	11
Speeds and gradeability	12
Main winch and auxiliary winch performance.....	12
Machine weights.....	13
MB: Main boom.....	14-20
FJ: Folding swing-away jib.....	22-24
WP: Work platform	26-27
Notes to Lifting Capacity.....	28
Technical Description	29
Crane specifications.....	30-31
Optional equipment.....	31

Key



	Counterweight		Jib offset angle
	Radius		Max. line pull
	Main boom		Rope length
	Folding swing-away jib		Rope
	Carbody counterweight		Hook block
	Overall width		Number of lines
	Roll / list angle		Assembly weight
	Total weight		Transport variant
	Hook block		Wire rope layer
	Overhaul ball		Total wire rope
	Travel speed		Winch layer diameter
	Gradeability		Wind speed in mph
	Working speeds		

SPECIFICATIONS



Specifications

Vehicle dimensions

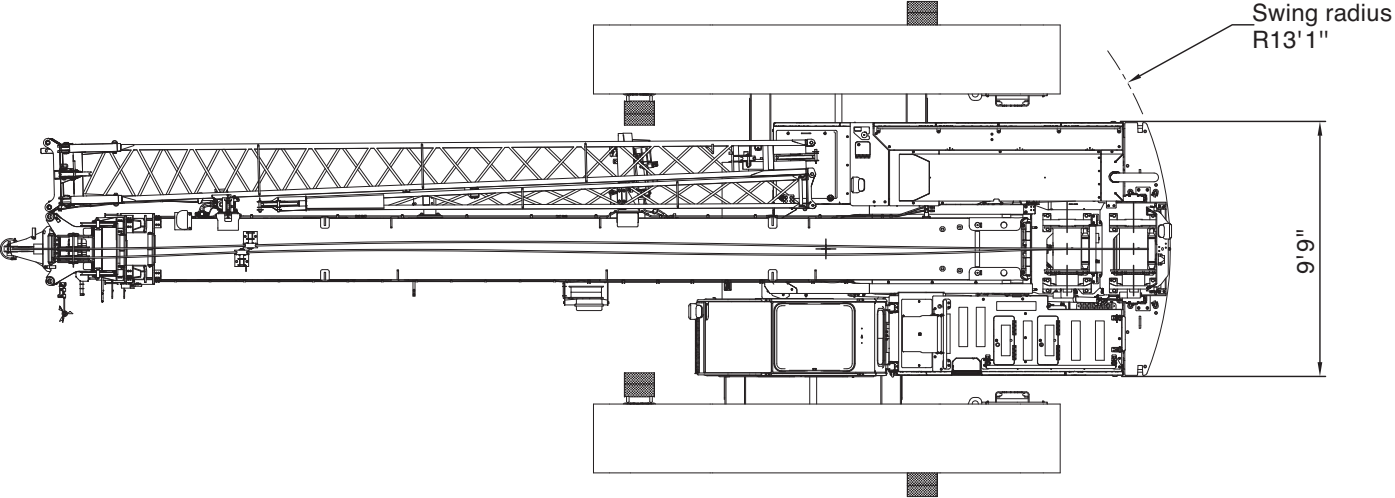
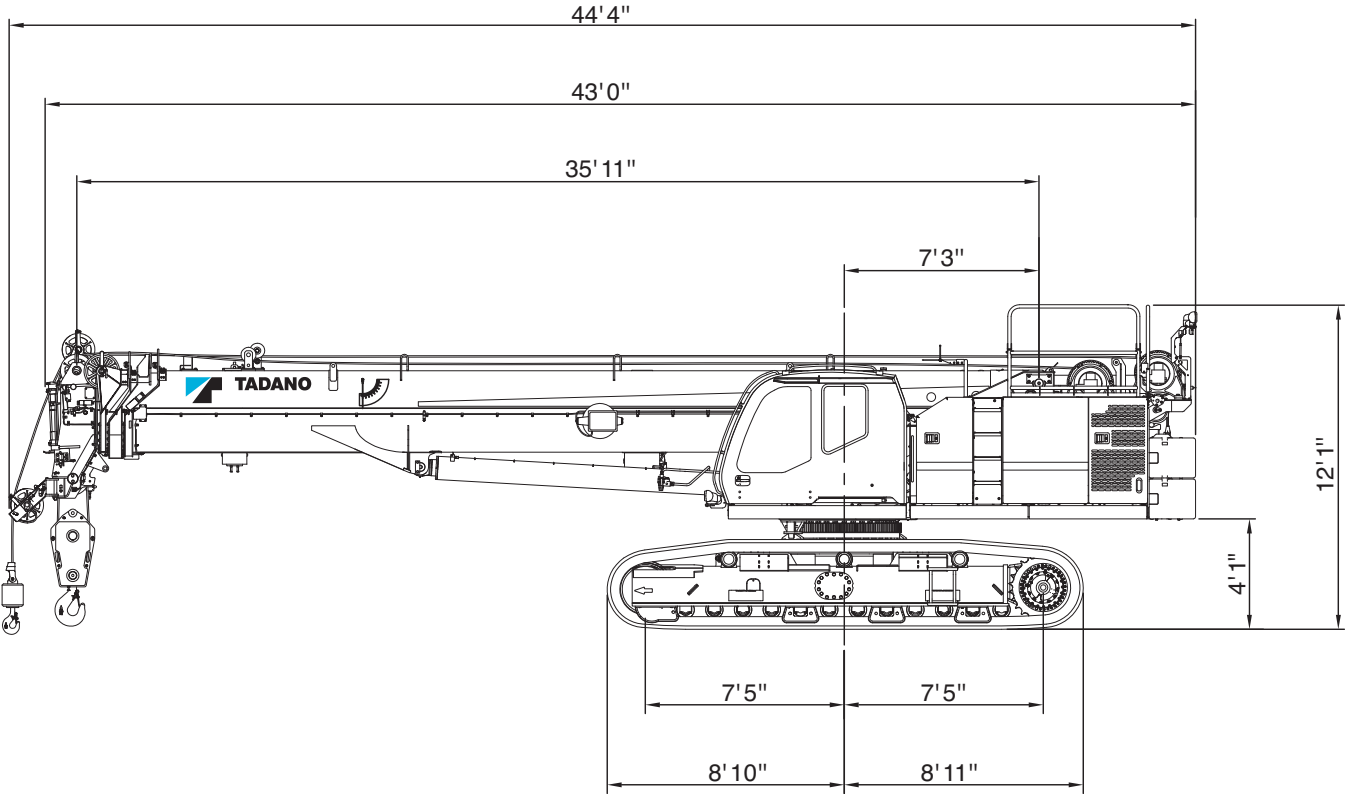

Specifications

Vehicle dimensions

Tracks retracted

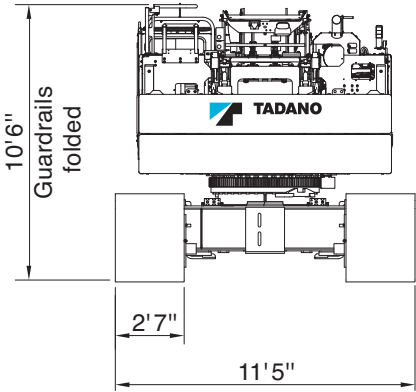

Tracks extended

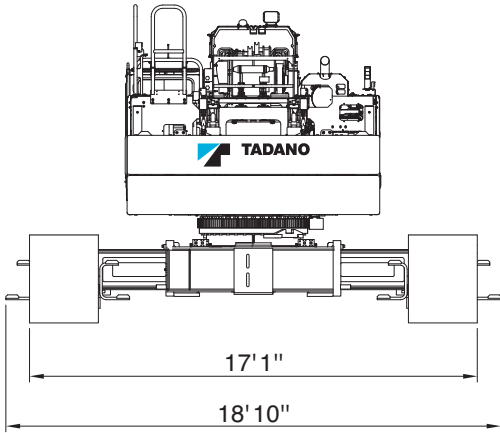

General dimensions

Overall length	43' 0"
Overall width (tracks extended)	17' 1"
Overall width (tracks retracted – standard counterweight)	11' 5"
Overall height (working)	12' 1"

TECHNICAL DATA FOR TRANSPORTATION



Transportation

Transport dimensions

Base jib 28.9 ft

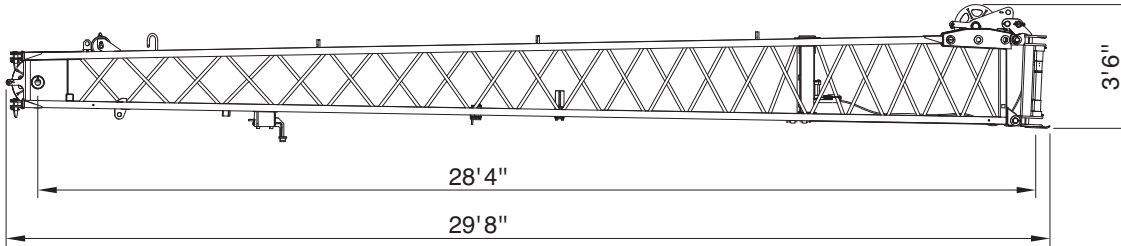

lb
1,351

Jib point 21.0 ft

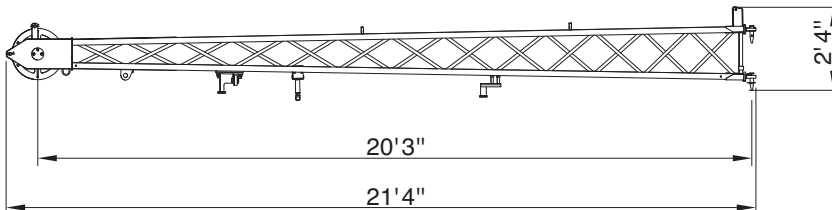

lb
518

Standard counterweight

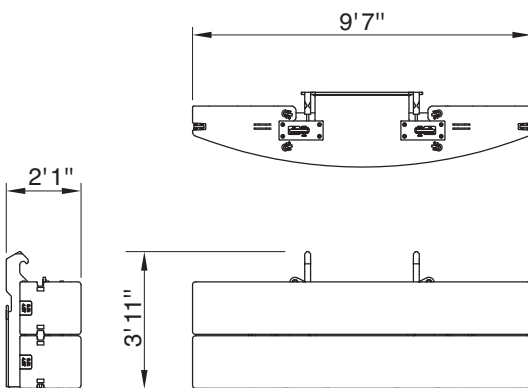

lb
17,400

Heavy counterweight (optional)

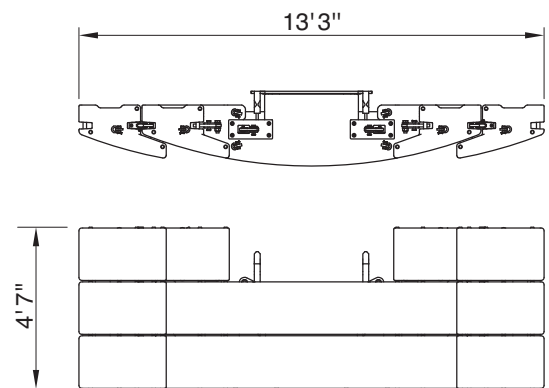

lb
28,200

TECHNICAL DATA FOR OPERATION







Operation

Speeds and gradeability

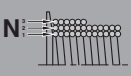
	0.8 mph / 1.8 mph		85 %
---	-------------------	---	------

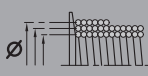
Main winch and auxiliary winch performance

					
1	13,310 lb	276.2 ft/min. 203.7 ft/min.	13.3 in.	98.9 ft	98.8 ft
2	12,262 lb	299.9 ft/min. 221.2 ft/min.	14.6 in.	107.3 ft	206.2 ft
3	11,366 lb	323.5 ft/min. 238.6 ft/min.	15.9 in.	115.8 ft	322.0 ft
4	10,593 lb	347.1 ft/min. 256.0 ft/min.	17.2 in.	124.3 ft	446.3 ft
5	9,918 lb	370.7 ft/min. 273.4 ft/min.	18.5 in.	132.7 ft	579.0 ft
6	9,324 lb	394.4 ft/min. 290.9 ft/min.	19.8 in.	141.2 ft	720.2 ft

Wire rope: 16 mm diameter rotation resistant. Line pulls are not based on wire rope strength.

Operation

Machine weights

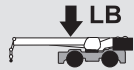

Standard equipment package

103,900 lb



Standard
Heavy (optional)

17,400 lb

28,200 lb

Standard Crane

with 4 section - 113' 10" boom, 17,400 lb standard counterweight, 2 winches with wire rope, and 31.5" 3-bar semi grouser track shoes

100,310 lb

Optional Equipment

Bi-fold jib base section: 28.9 ft

1,351 lb

Bi-fold jib tip section: 21.0 ft

518 lb



55 ton



6

1,500 lb



33 ton



3

798 lb



7.7 ton

220 lb

Optional track shoes: 35.4 inch, 3-bar semi grouser – additional weight

900 lb





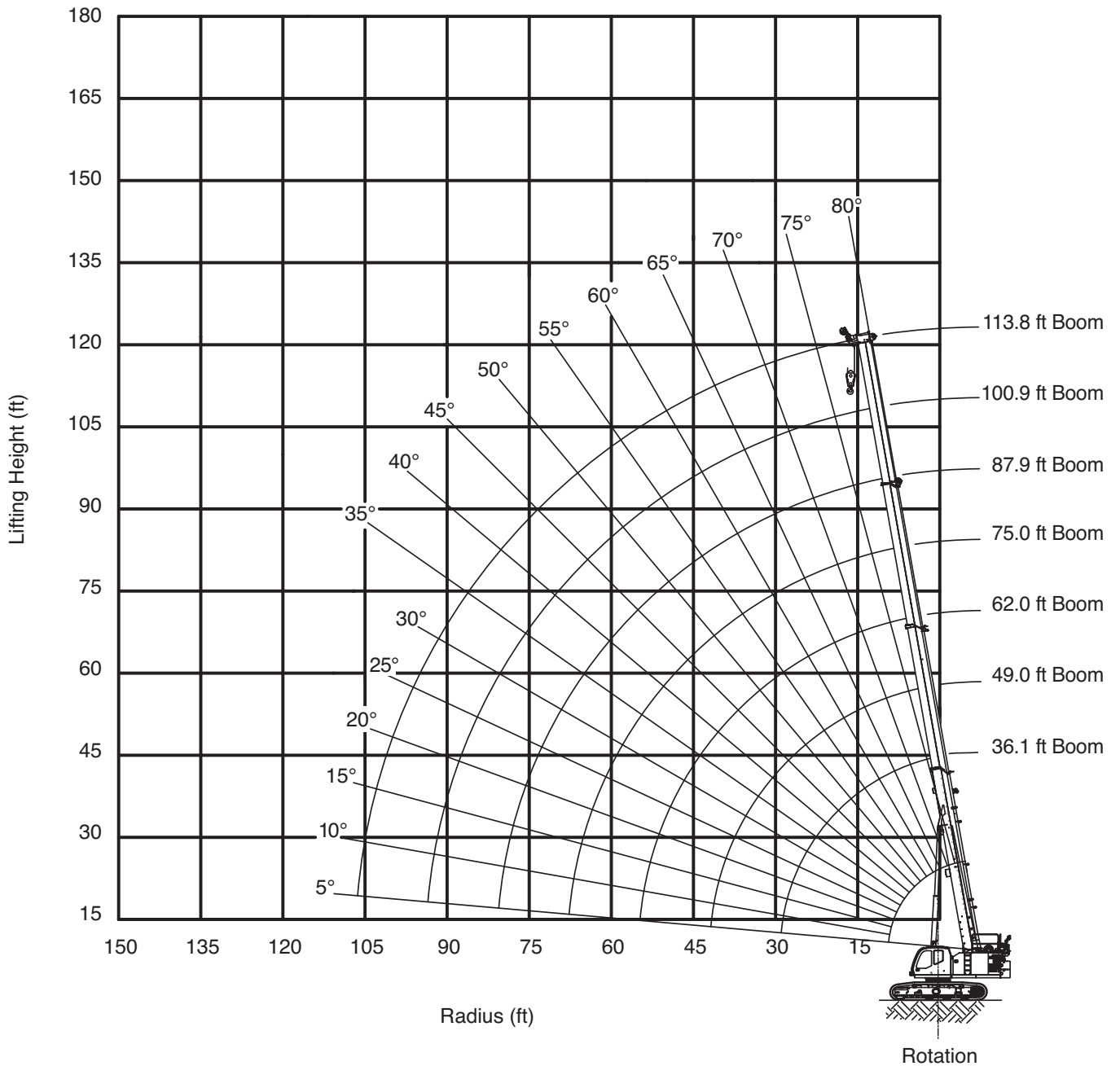

Optional heavy counterweight: 28,200 lb – additional weight

10,800 lb



Operation

Tracks fully extended – 360° – Up to 0.5° slope



17,400 lb		17' 1"		0.5°		20 mph		360°		ASME B30.5	
											
ft		36.1 ft	49.0 ft	62.0 ft	75.0 ft	87.9 ft	100.9 ft	113.8 ft	ft		
1,000 lb											
8	110.2	101.5	82.8	-	-	-	-	-	8		
10	101.4	97.1	82.8	40.0	-	-	-	-	10		
12	91.4	87.3	78.7	40.0	36.6	-	-	-	12		
15	79.4	75.8	69.0	40.0	36.5	36.1	-	-	15		
20	53.0	50.9	49.6	40.0	36.4	34.6	31.7	-	20		
25	36.8	37.9	38.3	35.3	35.9	33.6	27.4	-	25		
30	-	28.4	28.9	28.4	26.8	27.2	24.1	-	30		
35	-	22.3	22.8	23.1	20.9	21.3	21.4	-	35		
40	-	18.1	18.5	18.9	16.8	17.7	17.4	-	40		
45	-	-	15.4	15.7	14.2	15.1	14.4	-	45		
50	-	-	13.1	13.4	12.9	12.7	12.0	-	50		
55	-	-	-	11.5	11.6	10.8	10.1	-	55		
60	-	-	-	9.9	10.1	9.3	8.4	-	60		
65	-	-	-	8.7	8.8	7.9	7.1	-	65		
70	-	-	-	-	7.7	6.7	5.9	-	70		
75	-	-	-	-	6.7	5.8	5.0	-	75		
80	-	-	-	-	6.0	4.9	4.1	-	80		
85	-	-	-	-	-	4.2	3.4	-	85		
90	-	-	-	-	-	3.6	2.8	-	90		
95	-	-	-	-	-	-	2.2	-	95		
100	-	-	-	-	-	-	1.7	-	100		
105	-	-	-	-	-	-	*	-	105		
	12	10	8	6	4	4	4				

Load chart data is for reference, load charts supplied in the crane cab shall be used for lift planning.

An asterisk (*) on the chart indicates positions without rated loads. These areas are susceptible to instability in either the forward or backward direction. Even without a load, the boom should not be positioned in these configurations of the load chart to avoid tipping.

Operation

Tracks fully extended – 360° – Up to 0.5° slope

28,200 lb		17' 1"		0.5°		20 mph		360°		ASME B30.5			
36.1 ft		49.0 ft		62.0 ft		75.0 ft		87.9 ft		100.9 ft		113.8 ft	
ft	1,000 lb										ft		
8	110.2	101.5	82.8	-	-	-	-	-	-	-	-	8	
10	101.4	97.1	82.8	40.0	-	-	-	-	-	-	-	10	
12	91.4	87.3	78.7	40.0	36.6	-	-	-	-	-	-	12	
15	79.4	75.8	69.0	40.0	36.5	36.1	-	-	-	-	-	15	
20	63.8	61.9	56.6	40.0	36.4	34.6	31.7	-	-	-	-	20	
25	45.6	44.1	43.0	40.0	36.4	33.6	27.4	25.3	-	-	-	25	
30	-	35.3	35.7	32.9	31.6	28.9	24.1	21.5	-	-	-	30	
35	-	28.0	28.4	25.8	26.5	25.3	21.5	19.3	-	-	-	35	
40	-	22.9	23.3	23.0	21.5	21.8	19.3	17.5	-	-	-	40	
45	-	-	19.6	19.9	17.9	18.2	17.5	15.6	-	-	-	45	
50	-	-	16.7	17.0	15.1	15.4	15.6	13.4	-	-	-	50	
55	-	-	-	14.7	12.8	13.3	13.4	11.6	-	-	-	55	
60	-	-	-	12.9	11.0	12.2	11.6	10.1	-	-	-	60	
65	-	-	-	11.4	9.8	10.8	10.1	8.9	-	-	-	65	
70	-	-	-	-	9.1	9.5	8.9	7.7	-	-	-	70	
75	-	-	-	-	8.4	8.4	7.7	6.7	-	-	-	75	
80	-	-	-	-	7.9	7.5	6.7	5.8	-	-	-	80	
85	-	-	-	-	-	6.6	5.8	5.0	-	-	-	85	
90	-	-	-	-	-	5.8	5.0	4.3	-	-	-	90	
95	-	-	-	-	-	-	4.3	3.7	-	-	-	95	
100	-	-	-	-	-	-	3.7	3.2	-	-	-	100	
105	-	-	-	-	-	-	3.2	-	-	-	-	105	
	12	10	8	6	4	4	4	4	4	4	4		

Load chart data is for reference, load charts supplied in the crane cab shall be used for lift planning.

Operation

Tracks fully extended – 360° – Up to 4° slope



17,400 lb		17' 1"		4°		20 mph		360°		ASME B30.5	
ft	36.1 ft	49.0 ft	62.0 ft	75.0 ft	87.9 ft	100.9 ft	113.8 ft	ft			
									1,000 lb		
8	110.2	101.5	52.7	-	-	-	-	8			
10	101.4	97.1	52.7	40.7	-	-	-	10			
12	88.8	77.1	52.7	40.0	32.6	-	-	12			
15	65.1	57.5	51.8	40.0	32.6	28.7	-	15			
20	43.8	40.3	38.8	34.6	32.6	24.8	20.9	20			
25	32.3	31.0	29.8	28.7	25.2	24.0	20.9	25			
30	-	24.3	23.5	22.9	19.9	19.4	18.9	30			
35	-	19.7	19.2	18.7	16.0	16.8	15.5	35			
40	-	16.6	16.0	15.7	14.4	14.0	12.9	40			
45	-	-	13.6	13.4	13.0	11.9	10.8	45			
50	-	-	11.8	11.6	11.3	10.1	9.0	50			
55	-	-	-	10.1	9.9	8.6	7.6	55			
60	-	-	-	8.8	8.6	7.4	6.4	60			
65	-	-	-	7.8	7.6	6.3	5.3	65			
70	-	-	-	-	6.7	5.4	4.5	70			
75	-	-	-	-	5.9	4.7	3.7	75			
80	-	-	-	-	5.4	4.0	3.0	80			
85	-	-	-	-	-	3.5	2.5	85			
90	-	-	-	-	-	3.0	2.0	90			
95	-	-	-	-	-	-	1.5	95			
100	-	-	-	-	-	-	*	100			
105	-	-	-	-	-	-	*	105			
		12	10	8	6	4	4	4			

Load chart data is for reference, load charts supplied in the crane cab shall be used for lift planning.

An asterisk (*) on the chart indicates positions without rated loads. These areas are susceptible to instability in either the forward or backward direction. Even without a load, the boom should not be positioned in these configurations of the load chart to avoid tipping.

Operation







Tracks fully retracted – over front – Up to 0.5° slope

17,400 lb		11' 5"		0.5°		20 mph		ASME B30.5	
ft	36.1 ft	49.0 ft	62.0 ft	75.0 ft	87.9 ft	100.9 ft	113.8 ft	ft	
1,000 lb									
8	110.2	101.5	82.8	-	-	-	-	8	
10	101.4	97.1	82.8	40.0	-	-	-	10	
12	91.4	87.3	78.7	40.0	36.6	-	-	12	
15	79.4	75.8	69.0	40.0	36.5	36.1	-	15	
20	54.9	53.0	51.7	40.0	36.4	34.6	31.7	20	
25	37.7	38.8	38.8	36.2	36.4	33.6	27.4	25	
30	-	29.1	29.6	28.4	27.5	27.8	24.1	30	
35	-	22.9	23.3	23.7	21.5	21.8	21.5	35	
40	-	18.6	19.0	19.3	17.3	17.7	17.9	40	
45	-	-	15.8	16.1	14.2	15.5	14.7	45	
50	-	-	13.4	13.7	12.9	13.1	12.4	50	
55	-	-	-	11.8	11.7	11.1	10.5	55	
60	-	-	-	10.2	10.4	9.6	9.0	60	
65	-	-	-	9.0	9.1	8.3	7.7	65	
70	-	-	-	-	8.0	7.2	6.6	70	
75	-	-	-	-	7.1	6.3	5.7	75	
80	-	-	-	-	6.3	5.5	4.9	80	
85	-	-	-	-	-	4.9	4.3	85	
90	-	-	-	-	-	4.3	3.7	90	
95	-	-	-	-	-	-	3.1	95	
100	-	-	-	-	-	-	2.6	100	
105	-	-	-	-	-	-	2.1	105	
	12	10	8	6	4	4	4		

Load chart data is for reference, load charts supplied in the crane cab shall be used for lift planning.

Operation

Tracks fully extended – 360° – Up to 1.5° slope



0 lb		17' 1"		1.5°		20 mph		360°		ASME B30.5	
											
ft		36.1 ft	49.0 ft	62.0 ft	75.0 ft	87.9 ft	100.9 ft	113.8 ft	ft		
ft		1,000 lb									
8		110.2	101.5	82.8	-	-	-	-		8	
10		101.4	93.0	82.1	55.1	-	-	-		10	
12		71.8	66.0	61.4	40.0	40.0	-	-		12	
15		48.3	44.6	41.8	40.0	36.5	36.5	-		15	
20		29.5	30.4	30.5	30.4	26.5	27.2	24.2		20	
25		20.1	21.2	21.5	21.6	21.5	20.0	17.9		25	
30		-	15.6	16.0	16.2	16.2	14.9	13.6		30	
35		-	11.8	12.2	12.6	12.6	11.4	10.4		35	
40		-	9.1	9.6	9.9	10.0	8.9	7.9		40	
45		-	-	7.6	7.9	8.0	6.9	6.0		45	
50		-	-	6.0	6.3	6.5	5.4	4.6		50	
55		-	-	-	5.1	5.2	4.2	3.4		55	
60		-	-	-	4.1	4.2	3.2	2.4		60	
65		-	-	-	3.3	3.4	2.4	1.6		65	
70		-	-	-	-	2.7	1.7	*		70	
75		-	-	-	-	2.1	*	*		75	
80		-	-	-	-	1.7	*	*		80	
85		-	-	-	-	-	*	*		85	
90		-	-	-	-	-	*	*		90	
95		-	-	-	-	-	-	*		95	
100		-	-	-	-	-	-	*		100	
105		-	-	-	-	-	-	*		105	
		12	10	8	6	4	4	4			

Load chart data is for reference, load charts supplied in the crane cab shall be used for lift planning.

An asterisk (*) on the chart indicates positions without rated loads. These areas are susceptible to instability in either the forward or backward direction. Even without a load, the boom should not be positioned in these configurations of the load chart to avoid tipping.

Operation

Tracks fully retracted – over side – Up to 1.5° slope

17,400 lb		11' 5"		1.5°		20 mph		ASME B30.5	
ft	36.1 ft	49.0 ft	62.0 ft	75.0 ft	87.9 ft	100.9 ft	113.8 ft	ft	
ft	1,000 lb							ft	
8	110.2	*	*	-	-	-	-	8	
10	86.3	79.8	71.3	*	-	-	-	10	
12	64.3	60.0	56.4	40.0	34.7	-	-	12	
15	45.8	43.0	40.8	40.0	36.5	35.7	-	15	
20	29.9	30.3	30.1	29.9	26.9	26.8	24.2	20	
25	21.5	22.1	22.2	22.2	22.0	20.5	18.5	25	
30	-	16.9	17.1	17.2	17.2	16.1	14.6	30	
35	-	13.4	13.6	13.8	13.8	12.8	11.7	35	
40	-	10.9	11.1	11.3	11.3	10.4	9.5	40	
45	-	-	9.2	9.4	9.4	8.6	7.7	45	
50	-	-	7.7	7.9	7.9	7.1	6.3	50	
55	-	-	-	6.7	6.7	6.0	5.2	55	
60	-	-	-	5.7	5.8	5.0	4.3	60	
65	-	-	-	4.9	4.9	4.2	3.5	65	
70	-	-	-	-	4.3	3.5	2.8	70	
75	-	-	-	-	3.7	2.9	2.1	75	
80	-	-	-	-	3.2	2.2	*	80	
85	-	-	-	-	-	1.7	*	85	
90	-	-	-	-	-	*	*	90	
95	-	-	-	-	-	-	*	95	
100	-	-	-	-	-	-	*	100	
105	-	-	-	-	-	-	*	105	
	12	10	8	6	4	4	4		

Load chart data is for reference, load charts supplied in the crane cab shall be used for lift planning.

An asterisk (*) on the chart indicates positions without rated loads. These areas are susceptible to instability in either the forward or backward direction. Even without a load, the boom should not be positioned in these configurations of the load chart to avoid tipping.

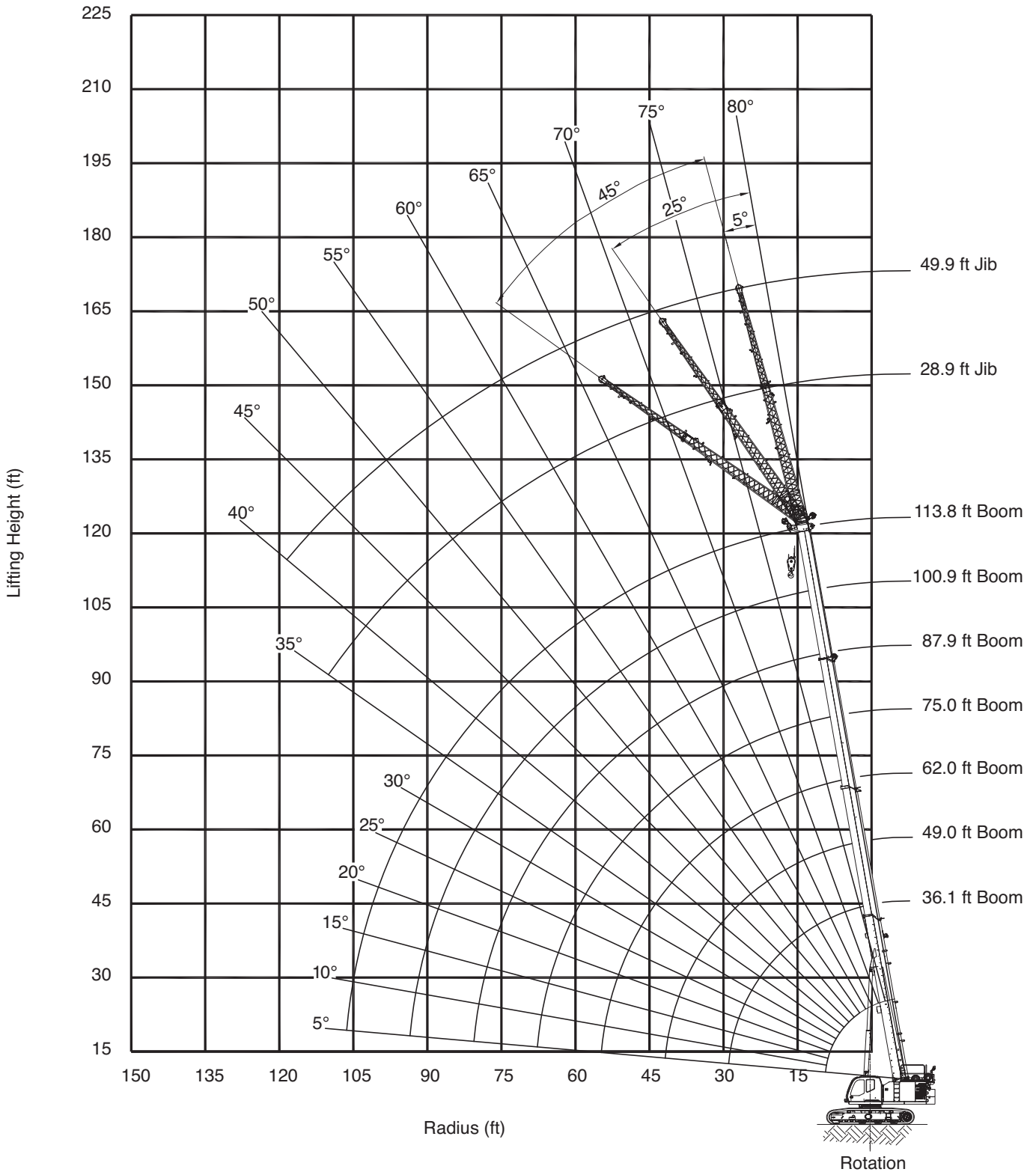

Operation

Tracks fully extended – 360° – Up to 0.5° slope – Folding jib

17,400 lb		17' 1"			0.5°			28.9 ft			20 mph			360°			ASME B30.5	
36.1 ft		62.0 ft			87.9 ft			100.9 ft			113.8 ft							
5°		25°		45°		5°		25°		45°		5°		25°		45°		
ft	1,000 lb															ft		
10	10.9	-	-	-	-	-	-	-	-	-	-	-	-	-	-	-	-	10
12	10.9	-	-	-	-	-	-	-	-	-	-	-	-	-	-	-	-	12
15	10.9	-	-	10.9	-	-	-	-	-	-	-	-	-	-	-	-	-	15
20	10.9	7.9	-	10.9	-	-	10.9	-	-	-	-	-	-	-	-	-	-	20
25	9.6	7.2	-	10.9	7.9	-	10.9	-	-	10.9	-	-	-	-	-	-	-	25
30	8.4	6.4	5.1	10.7	7.3	5.5	10.9	7.8	-	10.9	-	-	10.9	-	-	-	-	30
35	7.5	5.8	4.8	9.6	6.8	5.2	10.9	7.3	-	10.9	7.5	-	10.9	-	-	-	-	35
40	6.5	5.2	4.5	8.8	6.3	4.9	10.3	7.0	5.2	10.9	7.2	5.2	10.9	7.3	-	-	-	40
45	5.8	4.9	4.3	8.0	5.9	4.7	9.5	6.6	5.0	10.1	6.8	5.1	10.3	7.0	5.1	-	-	45
50	5.2	4.5	4.3	7.4	5.5	4.6	8.6	6.2	4.8	9.1	6.5	4.9	9.4	6.7	5.0	-	-	50
55	4.7	4.3	-	6.7	5.2	4.4	7.8	5.8	4.7	8.3	6.1	4.8	8.7	6.3	4.9	-	-	55
60	-	-	-	6.1	4.9	4.3	7.1	5.6	4.5	7.6	5.8	4.7	8.0	6.1	4.7	-	-	60
65	-	-	-	5.6	4.7	4.3	6.5	5.3	4.4	7.0	5.6	4.5	7.3	5.8	4.6	-	-	65
70	-	-	-	5.2	4.5	-	5.9	5.1	4.3	6.5	5.4	4.5	6.1	5.6	4.5	-	-	70
75	-	-	-	4.9	4.4	-	5.4	4.9	4.3	5.8	5.1	4.4	5.0	5.4	4.4	-	-	75
80	-	-	-	4.6	4.3	-	5.0	4.7	4.2	4.9	5.0	4.3	4.1	4.9	4.4	-	-	80
85	-	-	-	-	-	-	4.6	4.6	4.2	4.1	4.7	4.3	3.4	4.0	4.3	-	-	85
90	-	-	-	-	-	-	4.3	4.3	-	3.4	3.9	4.2	2.7	3.2	3.6	-	-	90
95	-	-	-	-	-	-	3.7	4.0	-	2.8	3.2	3.4	2.1	2.6	2.9	-	-	95
100	-	-	-	-	-	-	3.2	3.4	-	2.3	2.6	-	1.5	2.0	2.2	-	-	100
105	-	-	-	-	-	-	2.7	2.8	-	1.8	2.1	-	1.0	1.4	1.6	-	-	105
110	-	-	-	-	-	-	2.2	-	-	1.3	1.5	-	0.6	0.9	-	-	-	110
115	-	-	-	-	-	-	-	-	-	0.9	1.1	-	*	0.5	-	-	-	115
120	-	-	-	-	-	-	-	-	-	0.6	-	-	*	*	-	-	-	120
125	-	-	-	-	-	-	-	-	-	-	-	-	*	*	-	-	-	125
130	-	-	-	-	-	-	-	-	-	-	-	-	*	-	-	-	-	130
135	-	-	-	-	-	-	-	-	-	-	-	-	*	-	-	-	-	135
	1	1	1	1	1	1	1	1	1	1	1	1	1	1	1	1	1	

Load chart data is for reference, load charts supplied in the crane cab shall be used for lift planning.

An asterisk (*) on the chart indicates positions without rated loads. These areas are susceptible to instability in either the forward or backward direction. Even without a load, the boom should not be positioned in these configurations of the load chart to avoid tipping.

Operation



Tracks fully extended – 360° – Up to 0.5° slope – Folding jib

17,400 lb		17' 1"			0.5°			49.9 ft			20 mph			360°			ASME B30.5		
36.1 ft		62.0 ft			87.9 ft			100.9 ft			113.8 ft								
5°		25°			45°			5°			25°			45°					
ft		1,000 lb															ft		
15	8.7	-	-	-	-	-	-	-	-	-	-	-	-	-	-	-	-	15	
20	8.2	-	-	7.9	-	-	-	-	-	-	-	-	-	-	-	-	-	20	
25	7.0	-	-	7.9	-	-	-	-	-	-	-	-	-	-	-	-	-	25	
30	5.8	-	-	7.3	-	-	7.2	-	-	7.0	-	-	-	-	-	-	-	30	
35	5.0	3.7	-	6.4	-	-	7.2	-	-	7.0	-	-	6.7	-	-	-	-	35	
40	4.3	3.3	-	5.6	3.7	-	6.7	-	-	7.0	-	-	6.7	-	-	-	-	40	
45	3.8	3.0	2.5	5.0	3.4	-	6.0	3.6	-	6.4	3.7	-	6.7	-	-	-	-	45	
50	3.4	2.8	2.3	4.5	3.2	2.5	5.4	3.4	-	5.8	3.5	-	6.2	3.6	-	-	-	50	
55	3.1	2.6	2.2	4.1	3.0	2.4	4.9	3.2	2.4	5.3	3.3	-	5.6	3.4	-	-	-	55	
60	2.8	2.4	2.1	3.7	2.8	2.2	4.5	3.0	2.3	4.9	3.2	2.4	5.2	3.2	-	-	-	60	
65	2.5	2.2	2.0	3.4	2.6	2.2	4.1	2.9	2.3	4.5	3.0	2.3	4.8	3.1	2.3	-	-	65	
70	2.3	2.1	2.0	3.1	2.5	2.1	3.8	2.7	2.2	4.1	2.9	2.2	4.5	3.0	2.2	70	-	70	
75	2.2	2.0	-	2.9	2.3	2.0	3.5	2.6	2.1	3.9	2.7	2.2	4.2	2.8	2.2	75	-	75	
80	2.0	-	-	2.7	2.2	2.0	3.3	2.5	2.1	3.6	2.6	2.1	3.9	2.7	2.1	80	-	80	
85	-	-	-	2.5	2.1	1.9	3.1	2.4	2.0	3.4	2.5	2.1	3.7	2.6	2.1	85	-	85	
90	-	-	-	2.4	2.1	1.9	2.9	2.3	2.0	3.2	2.4	2.0	3.5	2.5	2.1	90	-	90	
95	-	-	-	2.2	2.0	-	2.8	2.2	2.0	3.0	2.3	2.0	3.0	2.4	2.0	95	-	95	
100	-	-	-	2.1	2.0	-	2.6	2.1	1.9	2.9	2.2	2.0	2.4	2.4	2.0	100	-	100	
105	-	-	-	2.0	-	-	2.5	2.1	1.9	2.6	2.2	1.9	1.9	2.3	2.0	105	-	105	
110	-	-	-	-	-	-	2.4	2.0	1.9	2.2	2.1	1.9	1.5	2.2	1.9	110	-	110	
115	-	-	-	-	-	-	2.2	2.0	-	1.8	2.1	1.9	1.1	1.7	1.9	115	-	115	
120	-	-	-	-	-	-	2.2	2.0	-	1.4	1.8	1.9	0.7	1.2	1.5	120	-	120	
125	-	-	-	-	-	-	1.9	2.0	-	1.1	1.4	-	0.3	0.8	1.1	125	-	125	
130	-	-	-	-	-	-	1.6	-	-	0.7	1.0	-	*	0.4	0.6	130	-	130	
135	-	-	-	-	-	-	-	-	-	0.4	0.6	-	*	*	-	135	-	135	
140	-	-	-	-	-	-	-	-	-	*	-	-	*	*	-	140	-	140	
145	-	-	-	-	-	-	-	-	-	-	-	-	*	*	-	145	-	145	
150	-	-	-	-	-	-	-	-	-	-	-	-	*	*	-	150	-	150	
155	-	-	-	-	-	-	-	-	-	-	-	-	*	-	-	155	-	155	
	1	1	1	1	1	1	1	1	1	1	1	1	1	1	1				

Load chart data is for reference, load charts supplied in the crane cab shall be used for lift planning.

An asterisk (*) on the chart indicates positions without rated loads. These areas are susceptible to instability in either the forward or backward direction. Even without a load, the boom should not be positioned in these configurations of the load chart to avoid tipping.

WP750 Work platform

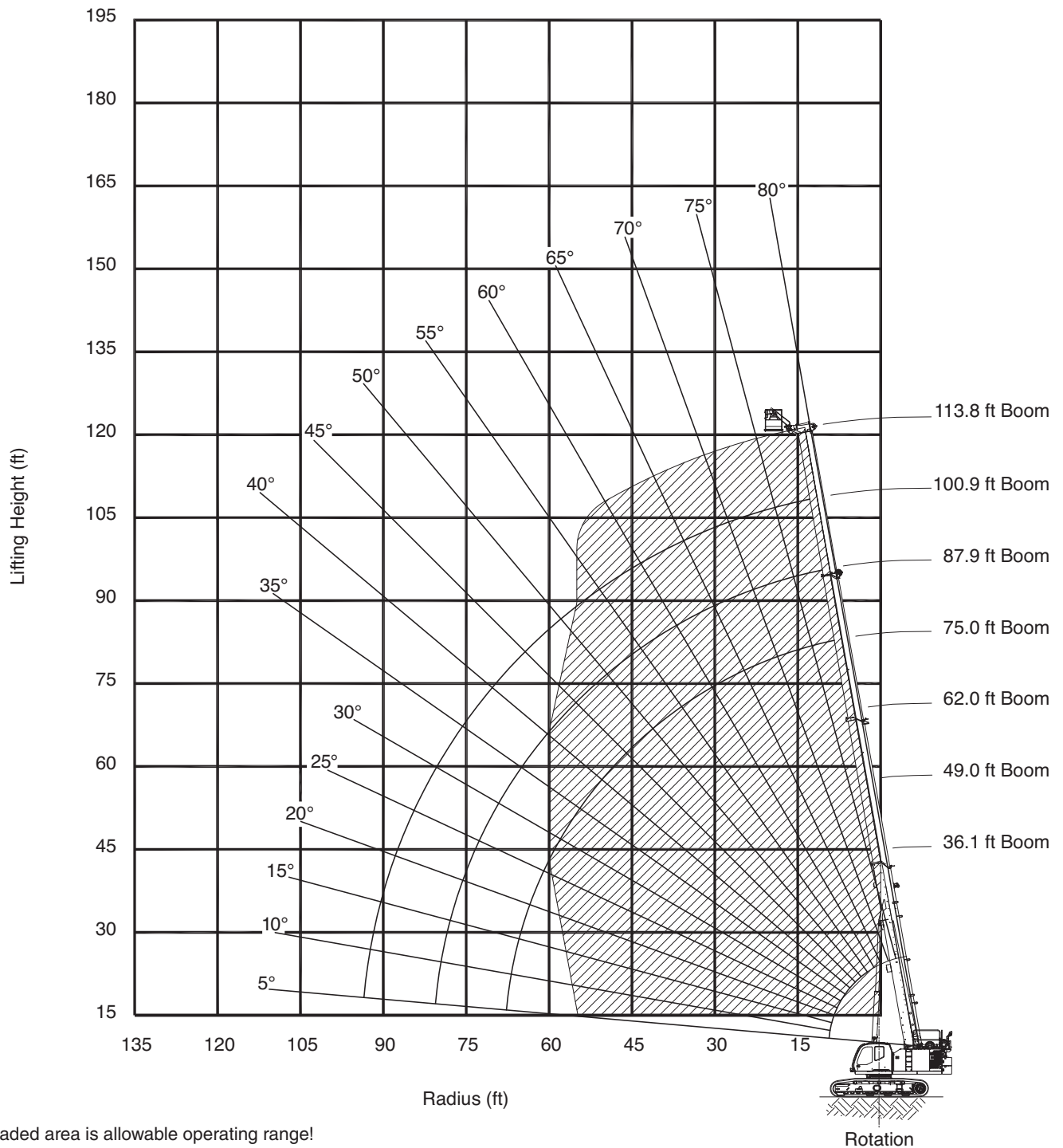

Shaded area is allowable operating range!

Limits of operation:

Max. load capacity = 750 lb · Max. radius when mounted on main boom = 60 ft · Max. occupancy = 2 persons

Notes:

1. It is permissible to leave the jibs stowed on the boom while operating with work platform mounted to the main boom.
2. The hook block(s) must be removed when using the work platform.

WARNING: Lifting a load during work platform operation is **not** allowed.

WARNING: Travelling the crane with person(s) in the work platform is **not** allowed.

WP750 Work platform

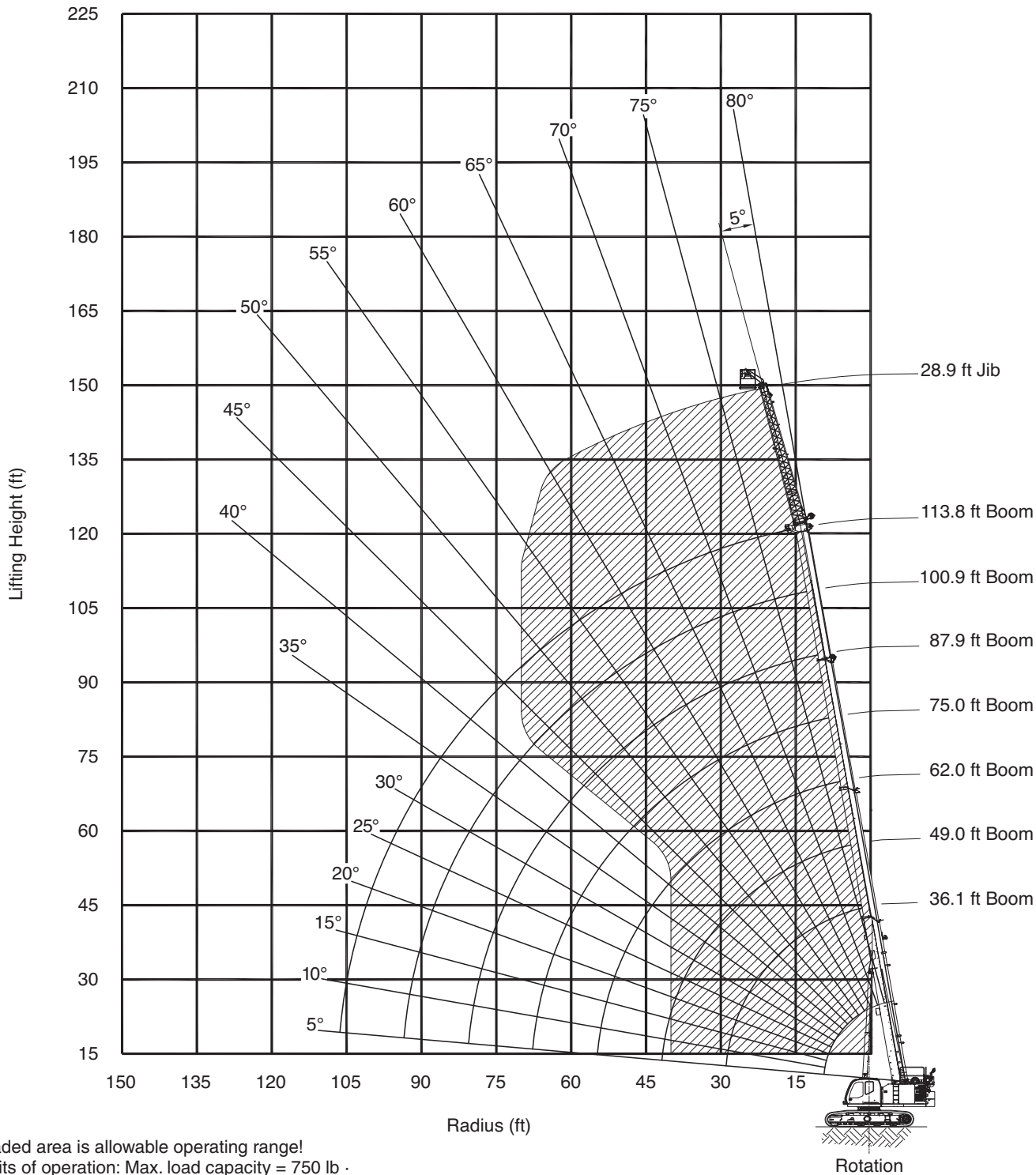

Shaded area is allowable operating range!

Limits of operation: Max. load capacity = 750 lb ·

Max. jib offset: 5° · Max. radius when mounted on jib = 70 ft · Max. occupancy = 2 persons

Notes:

1. It is permissible to leave the jib section stowed on the boom while operating with work platform mounted to the main boom.
2. The hook block(s) must be removed when using the work platform.

WARNING: Lifting a load during work platform operation is **not** allowed.

WARNING: Travelling the crane with person(s) in the work platform is **not** allowed.

Notes to Lifting Capacity

Definitions and Explanations

- Load capacity values in these charts are stated in lb x 1000.
- All ratings are for 360° of rotation unless otherwise specified on the chart.
- Load radius is defined as the horizontal distance from the axis of rotation (with no load) to the center of the lifting device after load is applied in feet (ft).
- Boom height dimensions are measured from ground to center of lower boom head sheave in feet (ft).
- Boom angle / boom length relationships given are an approximation of the resulting load radius, which should be an accurate measurement.
- Boom angle is the included angle between the longitudinal axis of the boom base section and the horizontal axis, after lifting load. The boom angle before lifting should be slightly greater than desired to account for boom deflection.
- Boom positions without rated loads in the charts are prohibited. These areas are indicated by an “*” and are susceptible to instability either in the forward direction or the backwards direction.
- It is acceptable to telescope boom with a load within the limits of rated capacities. However, boom angle, system hydraulic pressure, and/or boom lubrication may affect operation.
- Deduct the weight of the hook block, hook/ball, slings, spreader bar, or other suspended equipment from the listed rated capacities. This includes lifting accessories stowed on the boom such as jib, extension, and auger.
- Unless otherwise noted, travelling in low speed is allowed for all rated loads- reduce travel speed to minimize dynamic effects on the crane from swinging load, side loading, etc.
- This crane as originally manufactured meets the requirements of ASME B30.5 2014. Structure and stability have been tested in accordance with SAE J1063 and SAE J765.

Note

Data published herein is intended as a guide only and shall not be construed to warrant applicability for lifting purposes. Crane operation is subject to the computer charts and operation manual both supplied with the crane.

TECHNICAL DESCRIPTION



Technical Description

Crane specifications

Boom	<p>4-section full power telescoping boom with 2 extension modes. System consists of two double acting hydraulic cylinders with load holding valves and extension and retraction cables.</p> <p>Retracted length: 36' 1"</p> <p>Extended length: 113' 10" Extension time: 114 s</p> <p>Elevating angles: -1.5° to 80.5° Elevating time: 70 s</p> <p>Max. lifting height: 111' 1"</p> <p>Boom head: Six, 14.7 inch diameter main sheaves on heavy-duty roller bearings. Two, 14.7 inch diameter lead in sheaves on heavy-duty roller bearings. Designed for quick reeving of head and load block.</p>
Auxiliary boom head	<p>Quick reeve, single sheave mounted on a heavy-duty roller bearing. Allows single part reeving.</p>
Counterweight	<p>2 piece Standard counterweight design. Two upper counterweight configurations.</p> <p>Standard configuration = 17,400 lb</p> <p>Optional heavy configuration = 28,200 lb</p>
Winches	<p>Planetary geared two-speed winch includes a hydraulic motor, multidisc internal brake and counterbalance valve. Drum rotation indicator is included.</p> <p>Main winch:</p> <p>Rope diameter and length: 5/8 in x 615 ft</p> <p>Single line pull: 13,311 lb – first layer</p> <p>Single line speed: 347 ft/min – 4th layer</p> <p>Auxiliary winch:</p> <p>Rope diameter and length: 5/8 in x 350 ft</p> <p>Single line pull: 13,311 lb – first layer</p> <p>Single line speed: 347 ft/min – 4th layer</p>
Travel	<p>Each side frame contains a two-speed track drive with hydraulic axial piston motor and parking brake. Travel system provides skid steering and counter rotation.</p> <p>Travel speed: Low: 0.8 mph · High: 1.8 mph</p> <p>Gradeability (unladen): 85%</p> <p>Unladen ground pressure: 9.3 psi</p>
Swing	<p>Gear motor driving a planetary gear reducer with a shaft mounted pinion, external gear shear ball slew bearing bolted to the superstructure and the carbody allows the superstructure to rotate 360°.</p> <p>Swing speed: 0 - 2.0 rpm.</p> <p>Swing parking brake: Spring applied failsafe brake with hydraulic release that is controlled from the operators cab.</p> <p>Swing service brake: Hydraulically applied, controlled through foot actuated pedal.</p> <p>House lock system: 2-position house lock (boom over front or rear). Actuated from the operator's cab.</p>
Load moment indicator	<p>TADANO AML-C rated capacity limiter and anti-two block system: OPTI-WIDTH™ – OPTIMAL lifting performance at any track WIDTH.</p> <p>Control function shutdown. Audible and visual warnings.</p> <p>LCD screen provides a continuous display of working boom length, boom angle, working load radius, tip height, swing position, parts- offline (operator set), machine track configuration, relative load moment, maximum permissible load and actual load.</p> <p>Anti-two block weight allows quick reeving of hook block.</p> <p>Operator configurable working range limits with automatic soft stop.</p>
Frame	<p>The frame is an all-steel, welded structure, precision machined to accept attachment of the boom and swing components.</p>
Operators cab	<p>Fully-enclosed, air conditioned all-steel modular cab with lockable sliding door, acoustical lining, anti-slip floor and tinted safety glass.</p> <p>Cab tilts 20°. Rear view, winch view and right side view video cameras. Three remote control work lights.</p> <p>Vent window in the rear of the cab. Grab bars and steps are located for easy access to the cab. Defroster, heater, circulating fan. 2-speed windshield wiper, top glass wiper. Six-way adjustable fabric seat with headrest, seat belt. Dome light. Dry-chemical fire extinguisher. Four-way electronic armrest mounted joysticks control swing, main winch, auxiliary winch, boom hoist and boom extend. Foot pedals control the travel and swing service brake functions. Swing brake pedal is hydraulic. Selectable modes for fine control and travel. Travel function can be operated by foot pedals or joystick. Seat termination switch immediately disable all hydraulic functions as the operator rises from the seat. Functions can also be disabled by switch on console. Dash instrumentation: tachometer, hour meter, fuel gauge, and DEF level gauge. Indicators are provided for crane level, swing position, load moment, drum rotation, air filter restriction, engine oil temperature and pressure, hydraulic oil temperature and level, and hydraulic and air filter restriction, and low voltage.</p>

Technical Description

Crane specifications

Engine	Make/Model: Cummins QSB6.7 · Type: 6 cylinder, water cooled, 4 cycle · Aspiration: turbocharged and aftercooled · Max. output: 260 HP (194 kW) @2200 rpm · Max. torque: 730 lb-ft (990 Nm) @1500 rpm · Piston disp: 6.7 l · Emission Cert: U.S. EPA Tier 4f, Euromot Stage V · Alternator: 70 amp.		
Electrical system	24 VDC.		
Fuel system	Capacity: 85 gallons. Filtration: Inline fuel/water separator and engine mounted fuel filter.		
Side frames	Two welded steel side frames are paired with a track group. The side frames extend and retract hydraulically and are controlled from the cab. Track rollers: Three top and twelve bottom sealed rollers on each track frame Idler: Oil filled, self lubricating with spring type tensioner. Track shoes: 31.5 inch, 3-bar semi grouser.		
Hydraulic system	Hydraulic pumps: Two high pressure, variable axial piston pumps with load sense and power limiting control for crane functions. One gear pump for cooling loop. Directional valves: Multiple pressure and flow compensated valves with integrated relief valves controlled by electrical signals. Pump output: 154 gpm @2200 rpm engine speed. 5,000 psi maximum pressure. Reservoir: 185 gallons capacity, filler/breather, sight gauge, cleanout, and sump drain. Filtration: Three 5 micron, full flow tank mounted return filters with electrical clogging indicator. Two 2 micron pilot oil in-line pressure filters. Diagnostic ports: Provided for system, load sense, and pilot pressure.		
Bi-fold jib	Main jib: Total length: 28.9 ft	Max. lifting height: 140.7 ft	Offset angles: 5°, 25° and 45°
	Fly jib: Total length: 49.9 ft	Max. lifting height: 161.0 ft	Offset angles: 5°, 25° and 45°

Optional equipment

Hook blocks	55 ton quick reeve hook block – six, 16.1 inch steel sheaves, swivel hook and safety latch. 33 ton quick reeve hook block – three, 16.1 inch steel sheaves, swivel hook and safety latch.		
Overhaul ball	7.7 ton with swivel hook and safety latch.		
360° house lock	Actuated from the operator's cab.		
Track shoes	35.4 inch 3-bar semi grouser.		
Auger	Hydraulic auger boom package includes auger motor, hoses, fasteners, and stowage bracket assembly mounted to the 2nd stage section of boom for variable radius drilling.		
Tool circuit	Provides 5 gpm and 10 gpm @2,500 psi through a 50 ft twin hose reel with quick disconnect fittings to operate open center tools.		
High flow tool circuit	Provides 45 gpm @4800 psi.		
Controlled free fall hoists	Winches are available in controlled free fall configurations.		
Cold weather packages	Cold weather options are available for operation to -40°C (consult factory for application support).		
Work platform	Model WP750 – 36 inch x 72 inch, all steel, welded, two person platform with maximum capacity of 750 lb.		
Full function radio remote control package			
Boom mounted anemometer with cab display			
Automatic central lubrication system			

tac.sales@tadano.com
www.tadanoamericas.com

Tadano PanAmerican Operations
4242 W Greens Road, Houston, TX 77066
Phone: +1 (281) 869-0030



Lifting your dreams

