

TADANO CARGO CRANE

MODEL : **TM-ZE304MH**

CRANE SPECIFICATIONS

CRANE CAPACITY

3,030 kg at 2.5 m (4-part lines)

BOOM

Four-sectioned, fully powered partly synchronized telescoping boom of pentagonal box construction

Fully retracted length ----- 3.34 m

Fully extended length ----- 10.0 m

Extending speed ----- 6.66 m in 14 s

Elevation ----- Elevated by a double-acting hydraulic cylinder

Raising speed ----- 1° to 78° in 7.5 s

Boom point ----- 2 sheaves

WINCH

Hydraulic motor driven Spur gear speed reduction, provided with mechanical brake

Single line pull ----- 7.45 kN {760 kgf}

Single line speed ----- 76 m/min (at 4th layer)

Wire rope

Diameter x length ----- 8 mm x 63 m

Breaking strength ----- 43.1 kN {4.39 tf}

Construction ----- 7 x 7 + 6 x WS (26)

Hook block ----- 2 sheaves

HOOK BLOCK STOWING DEVICE

Hook-in (Mechanically stowed beneath boom top portion)

SLEWING

Hydraulic motor driven Worm gear speed reduction

Continuous 360° full circle slewing on ball bearing slew ring

Automatic slewing lock

Slewing speed ----- 2.5 min⁻¹ {rpm}

Specifications are subject to change without notice.

OUTRIGGERS

Manually operated beams and hydraulically operated jacks

Integral with crane frame

Extension width ----- Min. 2,000 mm center to center
(2,150 mm outer to outer)Mid. 2,700 mm center to center
(2,850 mm outer to outer)Max. 3,400 mm center to center
(3,550 mm outer to outer)HYDRAULIC SYSTEM

Hydraulic pump ----- Single gear pump

Hydraulic motors ----- Axial piston type for winch
Axial piston type for slewingControl valves ----- Multiple control valves with integral
safety valve

Oil tank capacity ----- Approx. 43.0 L

SAFETY DEVICES

Anti-two-block device

Boom angle indicator

Load indicator

Load meter

Hook safety latch

Spirit level

Hydraulic safety valves, check valves and holding valves

OPTIONAL EQUIPMENT

Emergency hydraulic pump

Outrigger pads

Oil cooler

Rear outriggers (outrigger beam extension type)

CRANE MASS

Approx. 1,170 kg

(Except crane options and munting parts.)

NOTE : Each operating speeds show the value when there is no load conditions and the pump delivery is the following conditions.

- 36 L/min (Slewing speed)
- 60 L/min (BOOM : Extending speed, Raising speed WINCH : Single line speed)

RATED LIFTING CAPACITIES (kg)

Crane Strength Rated Capacities

LOAD RADIUS	3.34 m / 5.57 m BOOM	LOAD RADIUS	7.78 m BOOM	LOAD RADIUS	10.0 m BOOM
2.3 m and below	3,030	2.7 m and below	2,330	4.0 m and below	1,030
2.5 m	3,030	3.2 m	2,030	5.0 m	880
3.0 m	2,480	3.5 m	1,830	6.0 m	750
3.5 m	2,080	4.0 m	1,630	7.0 m	650
4.0 m	1,780	4.5 m	1,480	8.0 m	580
4.5 m	1,580	5.0 m	1,330	9.0 m	510
5.0 m	1,380	5.5 m	1,230	9.8 m	480
5.37 m	1,280	6.0 m	1,130		
		6.5 m	1,030		
		7.0 m	950		
		7.58 m	880		

- NOTE :
1. The above numerical values of total rated loads are based on crane strength only. The total rated loads based on stability may lower than those in the above table depending on the loading conditions and the types of the chassis.
 2. This value includes the mass of lifting devices such as hook block (30kg).
 3. This load radius shows actual load radius which includes boom deflection.
 4. If the boom length exceeds the table value even a little, the performance is limited to the performance of the next boom length.
 5. When the boom length is 7.78 m, a half of the  mark on lateral face of the 3rd boom section is exposed out of 2nd boom section.

Empty Chassis Rated Capacities

Table A

LOAD RADIUS	3.34 m / 5.57 m BOOM		LOAD RADIUS	7.78 m BOOM		LOAD RADIUS	10.0 m BOOM	
	extension width of outriggers			extension width of outriggers			extension width of outriggers	
	MAX.	MIN.		MAX.			MAX.	
2.3 m and below	3,030	1,330	2.7 m and below	2,330	4.0 m and below	1,030		
2.6 m	2,580	1,080	3.2 m	1,650	5.0 m	730		
3.0 m	1,880	830	3.5 m	1,380	6.0 m	530		
3.5 m	1,380	630	4.0 m	1,080	7.0 m	430		
4.0 m	1,080	530	4.5 m	880	8.0 m	330		
4.5 m	880	430	5.0 m	730	9.0 m	280		
5.0 m	730	330	5.5 m	630	9.8 m	250		
5.37 m	680	330	6.0 m	530				
			6.5 m	480				
			7.0 m	430				
			7.58 m	380				

Table C

LOAD RADIUS	3.34 m / 5.57 m BOOM		LOAD RADIUS	7.78 m BOOM		LOAD RADIUS	10.0 m BOOM	
	extension width of outriggers			extension width of outriggers			extension width of outriggers	
	MAX.	MIN.		MAX.			MAX.	
2.3 m and below	3,030	1,430	2.7 m and below	2,330	4.0 m and below	1,030		
2.5 m	3,030	1,200	3.2 m	1,830	5.0 m	830		
3.0 m	2,080	930	3.5 m	1,580	6.0 m	630		
3.5 m	1,580	680	4.0 m	1,230	7.0 m	480		
4.0 m	1,230	580	4.5 m	980	8.0 m	400		
4.5 m	980	480	5.0 m	830	9.0 m	350		
5.0 m	830	380	5.5 m	730	9.8 m	330		
5.37 m	780	330	6.0 m	630				
			6.5 m	530				
			7.0 m	500				
			7.58 m	450				

Table D

LOAD RADIUS	3.34 m / 5.57 m BOOM		LOAD RADIUS	7.78 m BOOM		LOAD RADIUS	10.0 m BOOM	
	extension width of outriggers			extension width of outriggers			extension width of outriggers	
	MAX.	MIN.		MAX.			MAX.	
2.3 m and below	3,030	1,430	2.7 m and below	2,330	4.0 m and below	1,030		
2.5 m	3,030	1,200	3.2 m	2,030	5.0 m	880		
3.0 m	2,480	930	3.5 m	1,830	6.0 m	750		
3.5 m	2,080	680	4.0 m	1,630	7.0 m	650		
4.0 m	1,780	580	4.5 m	1,480	8.0 m	580		
4.5 m	1,580	480	5.0 m	1,330	9.0 m	510		
5.0 m	1,380	380	5.5 m	1,230	9.8 m	480		
5.37 m	1,280	330	6.0 m	1,130				
			6.5 m	1,030				
			7.0 m	950				
			7.58 m	880				

- NOTE :
1. Empty Chassis Rated Capacities in these tables depend on condition that crane is set level on firm level ground.
 2. This value includes the mass of lifting devices such as hook block (30kg).
 3. When the outriggers are extended to the middle width, read the capacities rated for the minimum extension width.
 4. This load radius shows actual load radius which includes boom deflection.
 5. If the boom length exceeds the table value even a little, the performance is limited to the performance of the next boom length.
 6. When the boom length is 7.78 m, a half of the \square mark on lateral face of the 3rd boom section is exposed out of 2nd boom section.
 7. Empty chassis rated lifting capacity varies according to the working area.
 - <over-side, over-rear area> : 100%
 - <over-front area> : 25%
 8. Empty Chassis Rated Capacities table A,C and D depend on the types of chassis. (The following table shows guidelines for bodywork vehicles that can achieve the rated lifting capacity tables A and C for vehicles. Be sure to carry out a stability inspection to determine which performance to apply.)

A	8.0 t ≤ GVW < 14.5 t
C	11.0 t ≤ GVW < 14.5 t, 4200 mm ≤ WB (*1)

*1 : From the front axle to the farthest rear axle.

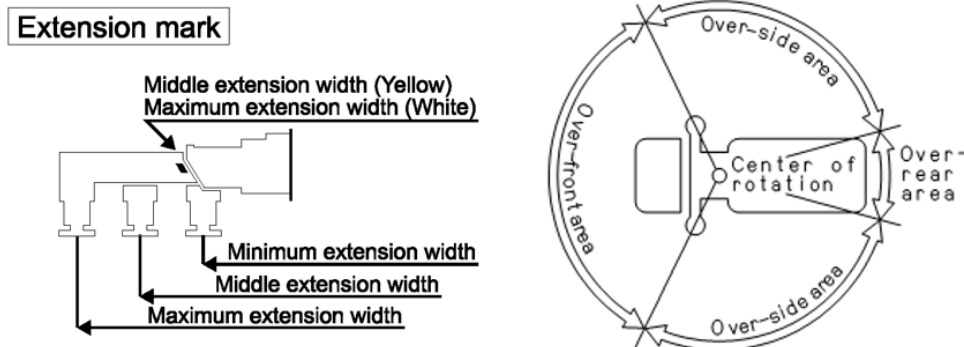

WORKING RANGE

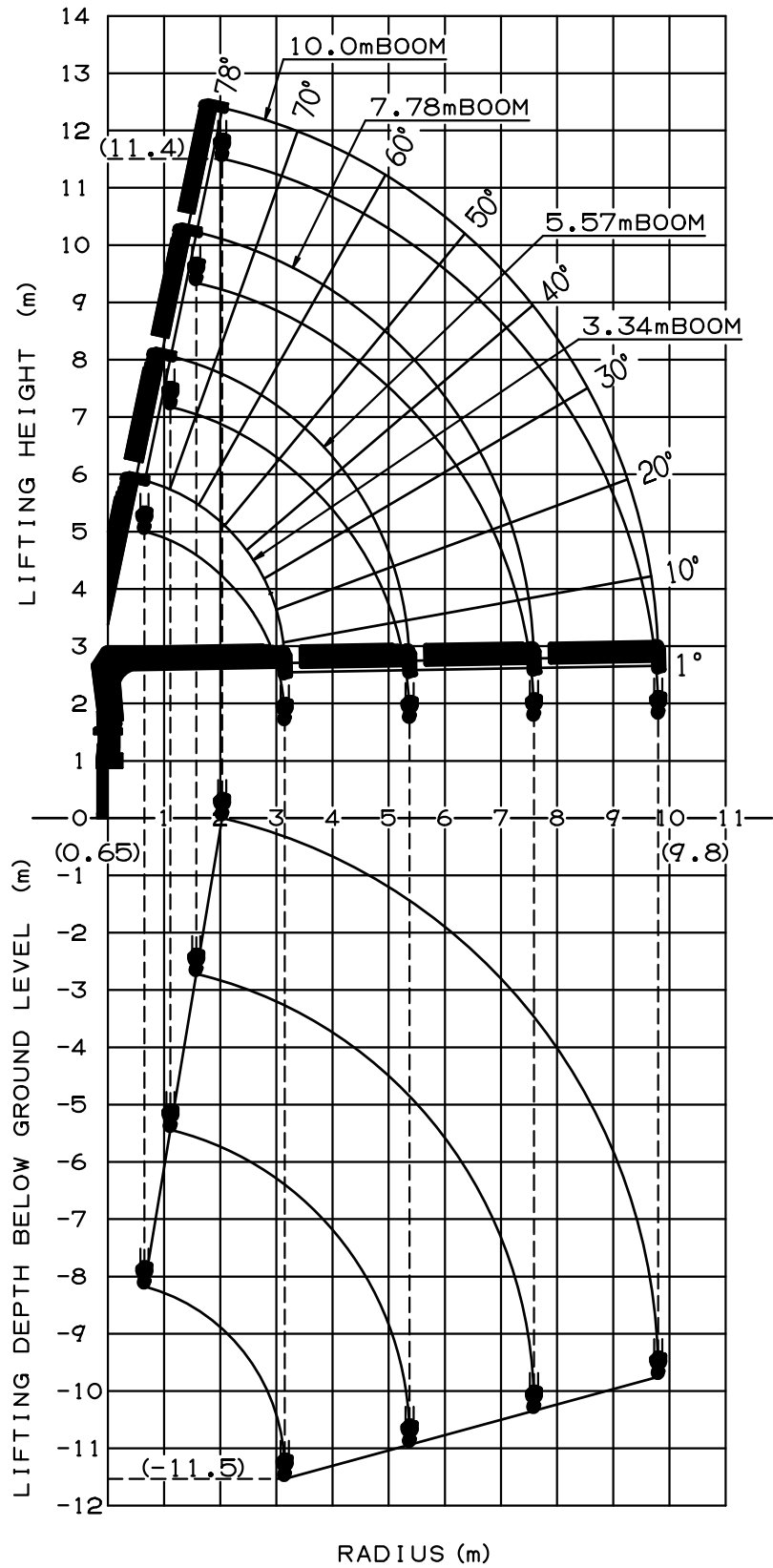

NOTE : The above lifting heights and boom angles are based on a straight (unladen) boom, and allowance should be made for boom deflection obtained under laden conditions.

DIMENSIONS

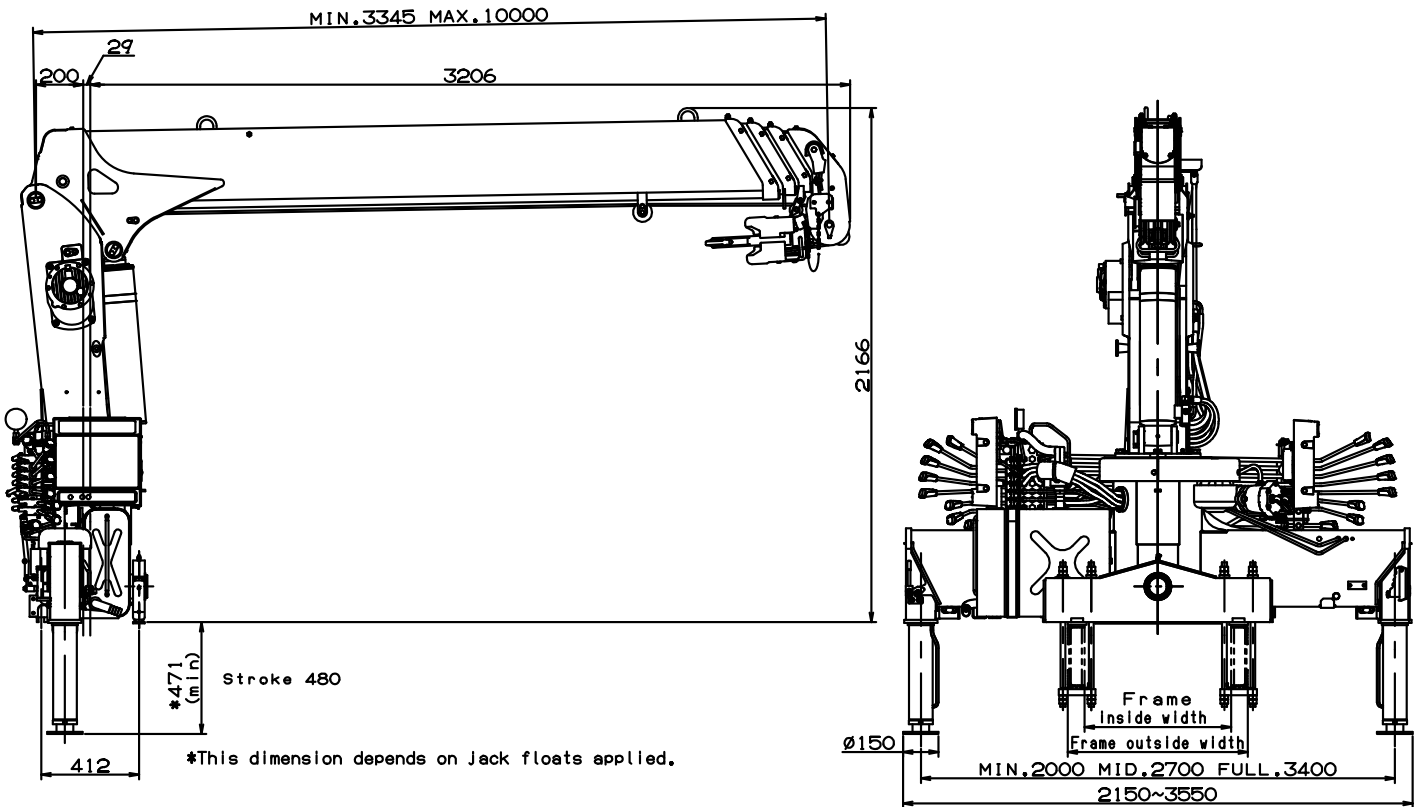

GENERAL DATA FOR SUITABLE TRUCKS

Gross vehicle weight	8,000 to 14,500 kg
P.T.O. torque	190 N·m {19.4 kgf·m} min.
P.T.O. revolution range of use (min. to max.)	Approx. 350 to 1,300 min ⁻¹ {rpm}
Width for crane mounting	Approx. 640 mm min.
Frame	Weight distribution and frame strength should be calculated for each truck
Frame width range (inside to outside)	Approx. 610 to 860 mm
Frame height (ground to chassis frame top) (*1)	Approx. 560 to 1,060 mm
Chassis frame section modulus (*2)	238 cm ³ min.

*1 Height of crane mounting surface is changed by crane bases.

*2 The chassis frame material must meet the following conditions at the crane mounting location.

— Yield point : 392 N/mm²

— Tensile strength : 540 N/mm²